



## **INSTALLATION INSTRUCTIONS** **AIR COOLED EVAPORATOR SATELLITE 2 - 15 TONS**

### **INTRODUCTION**

The unit is designed to meet many different air conditioning installation requirements. It's design permits floor or slab mounting, or suspension from ceilings. The unit may be turned on its side to permit passage through narrow entrances.

### **INSPECTION OF EQUIPMENT**

Upon receipt of the unit, inspect for visible or concealed damage. Report any damage to the freight carrier, and file a damage claim. Call 800-625-SKIL to request a fax of our written freight damage procedure. In the event even slight (cosmetic) damage is noted, IMMEDIATELY perform an inspection of the interior of the units paying particular attention to the major braze points on the coils, the set screws on the pulleys, and the connection to any interior valves. These are the areas most affected by G force impact and are the most common concealed damage sustained. REPORT ANY CONCEALED DAMAGE TO THE FREIGHT CARRIER AS SOON AS IT IS FOUND. If you do not know the carrier, please call customer support at 800-625-SKIL with unit serial number, they will provide the carrier's name and phone number to you.

All pulleys and belts must be checked to assure they have not loosened during transit. Set screws must be confirmed for tightness. Remove all foreign objects from the equipment. This includes accessories as they are often packed in the cabinets for shipment. Warranty documentation and Operation and Maintenance manuals are also shipped within the equipment (in their own zip-lock bag) and must be removed.

### **SELECTION OF INSTALLATION SITE**

Before unit is installed, a thorough study should be made of the structure. Careful consideration must be given to the location of wiring, condensate disposal, ductwork, and proper accessibility to the unit for maintenance and servicing. It is recommended that a minimum of 24" clearance space be allowed on each side of the unit to accommodate maintenance and servicing. Attention must also be given to the floor, ceiling, or wall load limitations.

### **UNIT MOUNTING**

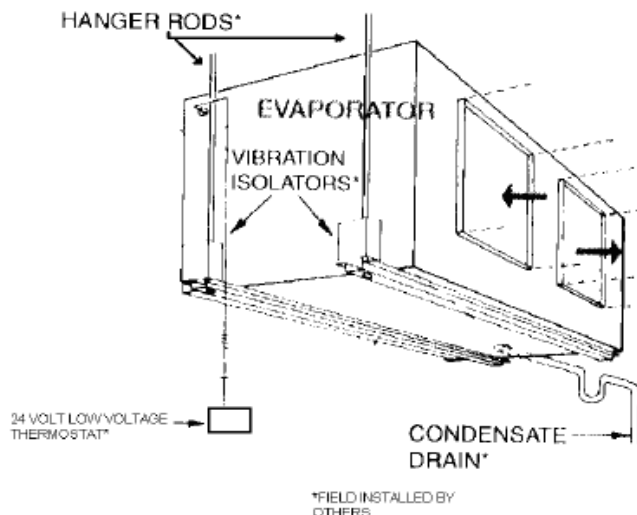

As shown in Fig. 1, unit is shipped as an integral package with a cross-member angle attached to both sides of the unit at each of the four mounting channels.

Fig. 1 can be used for dimensioning of mounting system if the evaporator section is separated from the outdoor condensing section, please refer to the mounting sequence in the O&M Manual on the outdoor condensing unit. If unit is to be hung, use field-supplied 3/8" diameter minimum hanging rods, with proper washers and locknuts.

**DIMENSIONS**

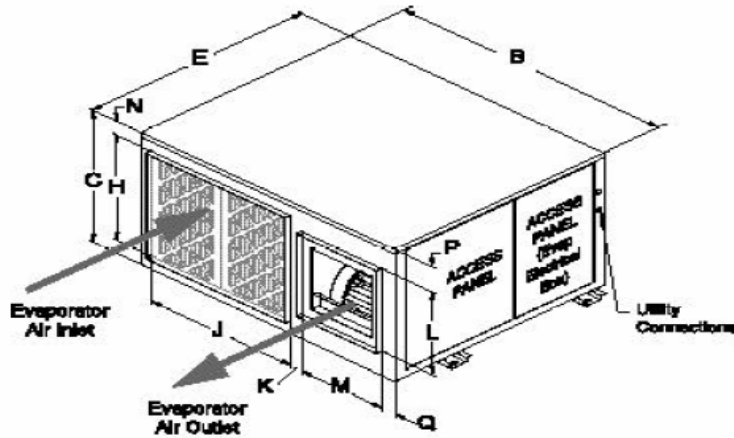

**FRONT / RIGHT / TOP**

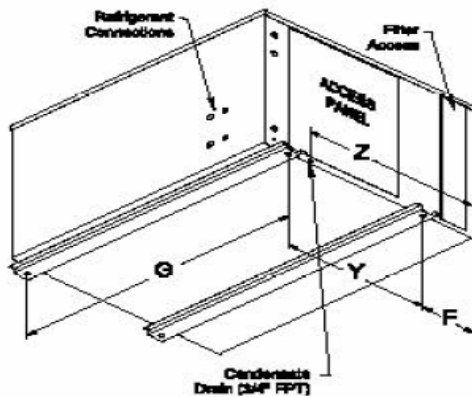

**REAR / LEFT / BOTTOM**

BAC & SCC-( ) MODEL SIZE	DIMENSIONS (inches)							
	B	C	E	F	G	H	J	K
024 & 036	43 1/8	22	38 3/8	13	44 3/4	18	20	2 3/4
	L	M	N	P	Q	Y	Z	
	14	12	1 1/4	2 1/4	5 13/16	22 5/8	24	

	B	C	E	F	G	H	J	K
048, 060, 072 & 096	51 1/4	29	42 1/4	11	53	23	28	2 1/2
	L	M	N	P	Q	Y	Z	
	18	16	3 1/4	5 11/16	2 7/8	27 1/4	25	

	B	C	E	F	G	H	J	K
120, 144, 180	70	29	34 1/2	7 1/2	71 1/2	25	46	2 1/2
	L	M	N	P	Q	Y	Z	
	20	18	1 1/4	2	1 3/4	24 3/4	20 1/2	

## **ELECTRICAL WIRING**

The unit is completely internally wired at the factory for normal supply voltages. Check unit specification plates for required voltages wire and fuse sizing. The factory wiring terminates to one control box which is located behind the outer access panel and is supplied with individual control box cover.

## **SPLIT SYSTEM**

If the unit is split see outdoor condensing system manual for installation.

## **CONDENSATE DRAINS**

The unit is equipped with one 3/4" IPS drain, when installed in those applications which may permit rain to enter the unit. It is EXTREMELY IMPORTANT that the lines attached to these connections contain a TRAP, to ensure positive draining. This equipment is a draw-thru design, which creates a slight negative pressure within the cabinet; therefore, it is highly recommended that the trap be primed with water prior to start-up of the unit.

## **FILTERS**

Throwaway filters are supplied with the unit and are an Underwriters Laboratories class 2 pleated extended surface type. Filters should be checked monthly for dirt accumulation and changed when necessary. Replacement filters must be the same as originally supplied. An auto-ship program is available which will provide replacement filters to the installation site on a regularly scheduled basis to provide both the filters and the reminder to change them. Call 800-625-SKIL to arrange for this handy service.

Remove the filter access panel located on the right front corner of the unit (Fig. 1).

**Note:** Unit must be shut off at the disconnect switch before the filter(s) are serviced and replaced. Be sure to check that the air flow arrows on the filters point in the proper direction. Airflow is INTO the equipment. 2&3-Ton Units require (1) 20x20x2 filter, 4, 5, 6, & 8-Ton Units require (2) 14x25x2 filters, and 10, 12, & 15-Ton Units require (3) 16x25x2 filters.

## **AIR FLOW**

The unit is equipped with adjustable motor and blower combinations for varied static pressures and airflow requirements. The drives have been selected such that, at the mid-position of the adjustable sheaves, the units will supply airflow with .3 external static pressure as follows:

PAA MODELS	EVAPORATOR	PAA MODELS	EVAPORATOR
2 Ton Unit	1100	8 Ton Unit	4000
3 Ton Unit	1600	10 Ton Unit	4000
4 Ton Unit	2200	12 Ton Unit	4800
5 Ton Unit	2500	15 Ton Unit	5400
6 Ton Unit	2800		

The drives may be adjusted for different static pressures. If such an adjustment is made, check that the motor current amp draw does not exceed the motor nameplate current by more than ten percent. On units with three phase fan motors, check for proper blower rotation at start-up. If the blower runs backwards, interchange two of the incoming power leads; this will reverse the direction of the motor.

## **OPTIONS**

### **ELECTRIC REHEAT**

The electric reheat option is in the form of a duct heater which is installed in the units 2-8ton and are a single power supply from the unit. Duct heaters for 10-15ton units must be installed a minimum of 4 feet downstream from the unit in the evaporator discharge duct. A separate power supply is required for the heater. Consult wiring diagrams in these instructions and note electric heater. The heater is actuated by the t-stat and is tied into the fan contactor.

## **MAINTENANCE PROCEDURES**

### **BLOWERS**

Skil-air air cooled units are provided with adjustable belt drive blower packages for both the evaporator and condenser sections. Check that the blower wheel is tight on the shaft and does not make contact with the housing. The squirrel cage should rotate freely. Check for restrictions or foreign material in the air circuit.

### **BELTS**

Drive belts should be examined prior to start-up and then monthly for wear and for correct tension. A too tight belt can cause bearing wear; a too loose belt will cause slippage and or noise. If the two legs of the belt are pressed in, midway between the pulley and the sheave, a properly tensioned belt will result in 1 inch to 1 ½ inches of movement. Belt tension can be adjusted by means of the adjusting bolt attached to the motor bracket. Larger units may have motors mounted to a support on the bottom pan, which requires loosening of four nuts to adjust the motor location and change belt position.

### **REFRIGERATION SYSTEMS**

All Skil-air systems contain a liquid line sight glass on each circuit. If bubbles appear in the sight glass, the system is either undercharged with refrigerant, or there may be a restriction in the liquid line up stream of the sight glass. The sight glass contains a moisture indicator, which changes color when moisture is present in the system. **If sight glass appearance is abnormal, servicing is required to determine the cause.**

### **EVAPORATOR AND CONDENSER COILS**

Check semi-monthly the condition of the face of both the evaporator and condenser coils. A dirty condenser coil will cause high condensing pressures, resulting in higher power consumption and possibly system shut down by the high-pressure safety control. A dirty evaporator coil will reduce unit capacity and eventually will cause shut down by the low-pressure safety control.